

N 30, Built-in microwave oven, 50 x 38 cm, Black
HLAWG25S3B



COOKING PASSION SINCE 1877



Built-in microwave for upper cabinets

- ✓ Microwave - high wattage and low effort for quick meals
- ✓ Side-opening hinged door - A smart twist for the elevated installation.
- ✓ LED-Display - simple, straightforward for clear reading
- ✓ Control Dials & One-Touch Buttons - select the right programme using your intuition
- ✓ Automatic programmes - Your kitchen helper with just the right default settings.

Features

Technical Data

Type of micro-wave oven : MW only
Type of control : Electronic
Color / Material Front : Black
Cavity dimensions : 180 x 280 x 300 mm
Approval certificates : CE, E17D UKCA marking
Length of electrical supply cord : 130 cm
Net weight : 15.0 kg
Gross weight : 16.6 kg
EAN code : 4242004262848
Maximum micro-wave power : 800 W
Connection rating : 1270 W
Fuse protection : 10 A
Voltage : 230-240 V
Frequency : 50 Hz
Plug type : GB plug
Cavity dimensions : 180 x 280 x 300 mm



4 242004 262848

N 30, Built-in microwave oven, 50 x 38 cm, Black
H1AWG25S3B



COOKING PASSION SINCE 1877

Features

Design

- LED display, red
- Electronic clock timer
- Elongated designed dials, Membrane keys, Start button
- User-friendly electronics: extremely easy and comfortable operation
- Cavity inner surface: lacquered grey
- Left hinged door
- Open door button

Features

- Quick Start Button: one tap to maximum microwave power for 30 seconds
- Favourite button for individual settings (1 setting)
- Control panel lock
Automatic safety switch off Door contact switch
- Cooling fan
- LED light
- 27 cm Glass turntable

Cleaning

- EasyClean

Programmes/functions

- 90-180-360-600-800 Watts and the following options 180 W, 360 W, 600 W, 800 W, 90 W
- Number of automatic programmes: 7 PC
- 4 defrost and 3 cooking programmes in microwave function

Technical information

- Cavity volume: 20 l
- 130 cm Cable length
- Total connected load electric: 1.27 KW
- Nominal voltage: 230 - 240 V
- Builds into a 50cm wide wall cupboard. Trim included.

Performance/technical information

- Appliance dimension (hxwx): 382 mm x 495 mm x 335 mm
- Niche dimension (hxwx): 362 mm - 365 mm x 460 mm - 468 mm x 320 mm
- Please refer to the dimensions provided in the installation manual

N 30, Built-in microwave oven, 50 x 38 cm, Black
H1AWG25S3B

Dimensioned drawings

measurements in mm
Installation of a 20 l microwave in a
wall cabinet

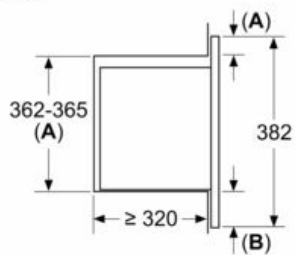

A: Overhang at top:
Recess 362: 6 mm
Recess 365: 3 mm
B: Overhang at bottom: 14 mm

measurements in mm

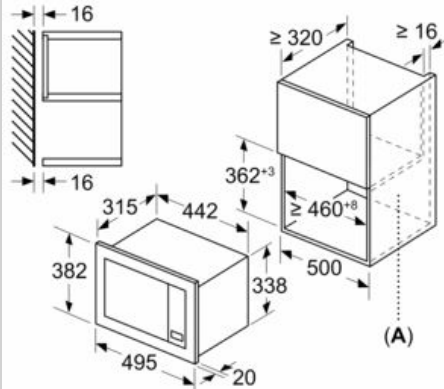

A: Back panel open